

## Nomad Flo SPC Stone Polymer Composite Flooring

### Installation Instructions (Herringbone pattern)

Read all instructions before installing. Incorrect installation will invalidate and void warranty.

#### IMPORTANT

- Product is intended for indoor use only.
- Product should not be used in areas with high risk of flooding (sauna, indoor swimming pool, shower zone, etc).
- Product is meant to be installed using a floating method only.
- Product includes an attached acoustic underlayment. In case you want to improve acoustic properties of your flooring, you can install an additional underlayment. It has to be recommended for vinyl flooring with maximum thickness of 1.6mm.
- Temperature before, during and after installation, during the use of flooring, should be kept between 18°C and 28°C with a humidity range of 35-65%.
- Always install your flooring in bright daylight to observe any imperfections. We will not be held responsible for any costs related to installation of the product with visible defects.

#### BEFORE INSTALLATION

- Product should be stored in boxes horizontally at all times.
- Room temperature and humidity of installation area should be consistent with normal, year-round conditions for at least one week before installation of flooring.
- Product is required to acclimate to the environment in which it will be used at least 48 hours prior to installation.
- Make sure a 5mm space is left between planks and walls or other obstructions such as pipes, stairs, door frames, etc.
- Do not install the product over expansion joints.
- Do not install kitchen cabinets or island over the product.
- Do not install planks lengthwise and widthwise across distances that exceed 18 metres. If they exceed these limitations, separate the areas using a T-molding.

#### APPROPRIATE SUBSTRATE FOR INSTALLATION

- Product can be installed over a variety of subfloor surfaces such as concrete, plywood, OSB and other existing hard surfaces (wood, ceramic, resilient coverings).
- Ensure the surface is structurally sound, flat, dry and clean.
- Surface must be level to 3mm per 2m radius. Maximum deflection should be no more than 1mm.
- Surface must be free of debris, dust and other contaminants.
- Substrate must not hold excessive moisture. Moisture content is to be maximum 2.0% for cement substrate and 0.5% for anhydrite substrate (CM method).

## RADIANT-HEATED SUBFLOOR

- Product can be installed over embedded radiant-heated system and electric heating mats as long as the subfloor temperature does not exceed 27°C. It is required to instal a temperature regulator and a temperature indicator.
- In case of embedded radiant-heated systems in all phases – construction of the system, drying and heating – instructions of the system supplier and respective norms have to be followed and confirmed in a written protocol.
- For radiant-heated subfloor moisture content is to be maximum 1.5% (cement) and 0.3% (anhydrite).
- In case of underfloor heating, the width of expansion joints should be increased to 5mm, if the floor area is to be greater than 50 m<sup>2</sup>.
- Temperature settings of the heating system during operation must ensure that the floor is not exposed to large temperature fluctuations.
- Space in which the product is to be installed must not contain both heated and unheated areas, unless there are adequate expansion joints to separate these areas.

## INSTALLATION

1. Choose a wall to start at and begin installing at the left corner. Start with an A-plank and place it with its long side marking facing the left wall at an angle of 45°. Make sure that the distance between the left wall and the plank is less than the length of one plank.
2. Continue with a B-plank. Press the long side of the B-plank at an angle against the short side of the previous installed A-plank. Fold down the B-plank flat to the floor to lock the planks tightly together. Check that the grooves on the two planks form a continuous line.
3. Next panel is an A-plank. Press the long side of the new A-plank at an angle against the short side of the previous B-plank and fold down. Continue like this with as many planks as may fit along the starting wall.

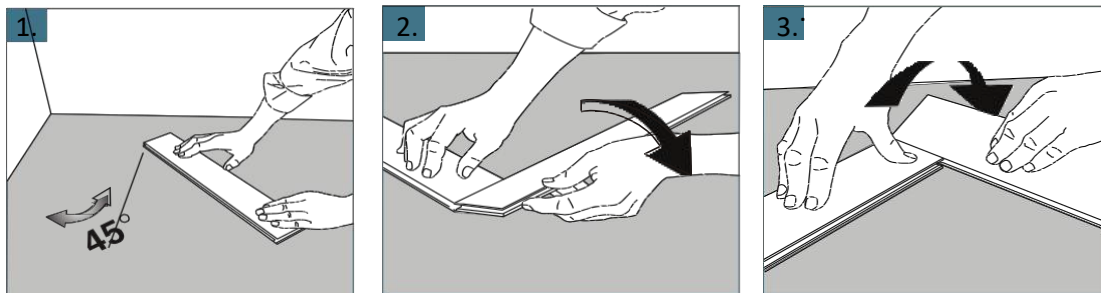

4. Check that the first row of planks is centered along the starting wall. Make sure that the distance to the walls on both sides are less than the length of one plank. If not, add a plank at the right side.
5. Measure and cut the end plank to size using a fine toothed saw. Finish the first row with the cut end plank. Make sure that you leave a gap of 5mm to each wall.

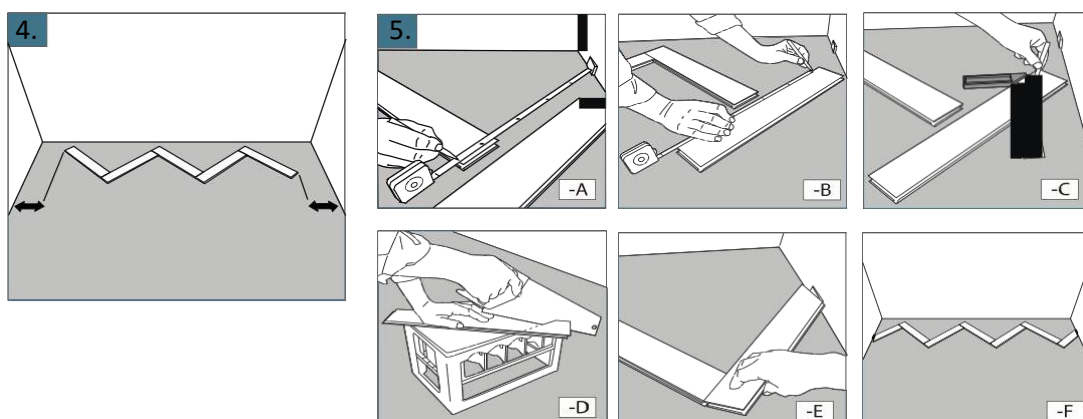

- 6. Start the next row with an A-plank. Place the new plank against the previous row and fold down.
- 7. Continue from the left to the right and install all the A-planks in the second row. Finish with a piece of plank cut to size (step 5).
- 8. Now work in the opposite direction, from the right to the left and install all the B-planks in the second row. Finish with a piece of plank cut to size (step 5.)

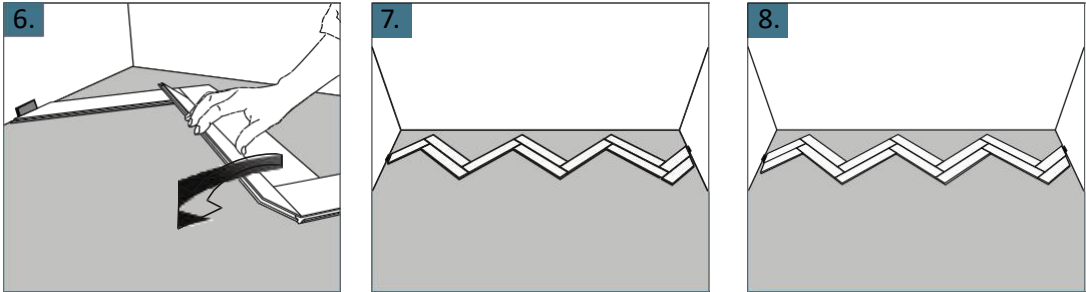

- 9. Install additional rows to complete four full rows.
- 10. The first four rows have to be cut parallel to the wall. Measure and mark where to cut the planks at a fixed distance to the wall.
- 11. Number the planks. This will allow you to keep the planks in order. Dismantle the planks and cut them to size along the previous marked line.

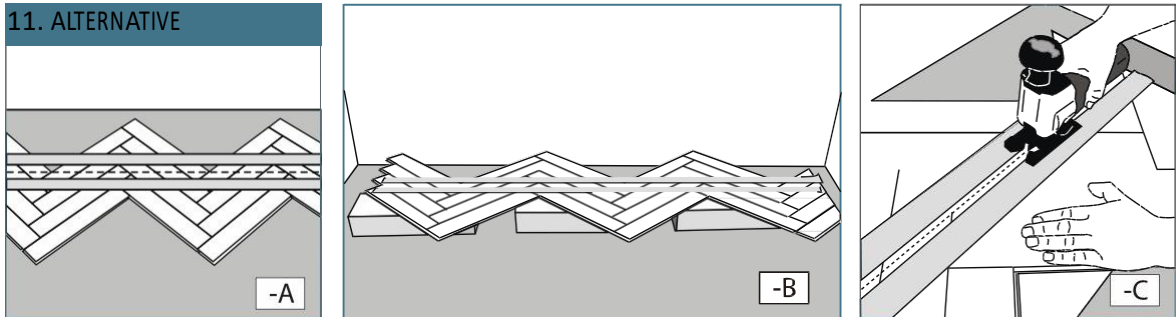
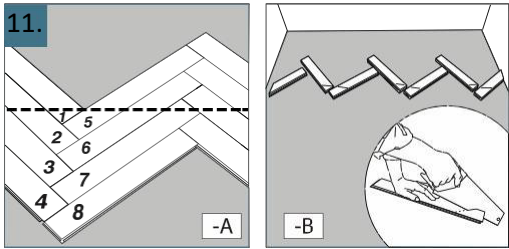
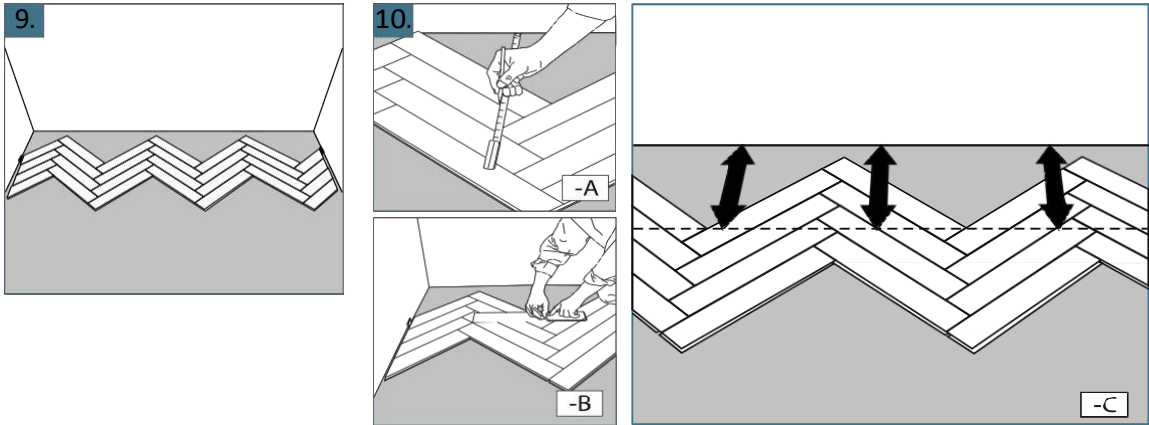

11. Alternative way to cut the first rows

Leave the left end-planks uninstalled. Tape along the marked line and place the flooring on top of a few flooring packages. Cut along the marked line. Then put the adjusted rows into place. Complete the first rows by installing the remaining end-planks. Start with the end-planks in the last row and finish at the first row.

12. Connect the cut starting planks to form triangular shapes one by one. Start installing the triangles from the left corner. It is recommended to use glue to fix the smallest parts of the triangles into place by applying a small quantity of glue inside the groove.

13. Connect the triangles by installing a few additional rows of planks. Start each row from the left to the right with the A-planks, finish with the cut piece of plank (step 5) and then install all the B-planks in the row. Finish with the left end planks cut to size.

14. Put in spacers between the flooring and the wall to ensure an expansion gap of 5mm.

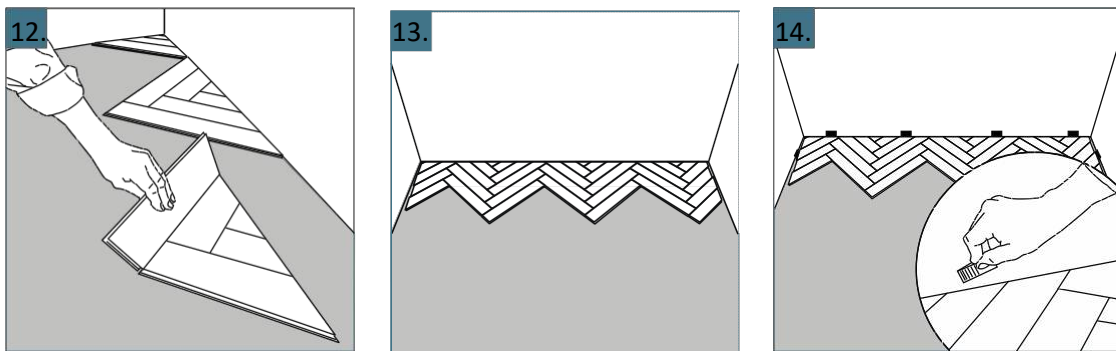

15. Start each subsequent row by installing the A-planks from the left to the right and complete the row by laying the B-planks from the right to the left.

16. Measure and cut the planks in the last row to size. It is recommended to use glue to install the smallest pieces of planks. Apply a small quantity of glue inside the groove.

17. Remove the spacers and cover the expansion gap with skirting boards.

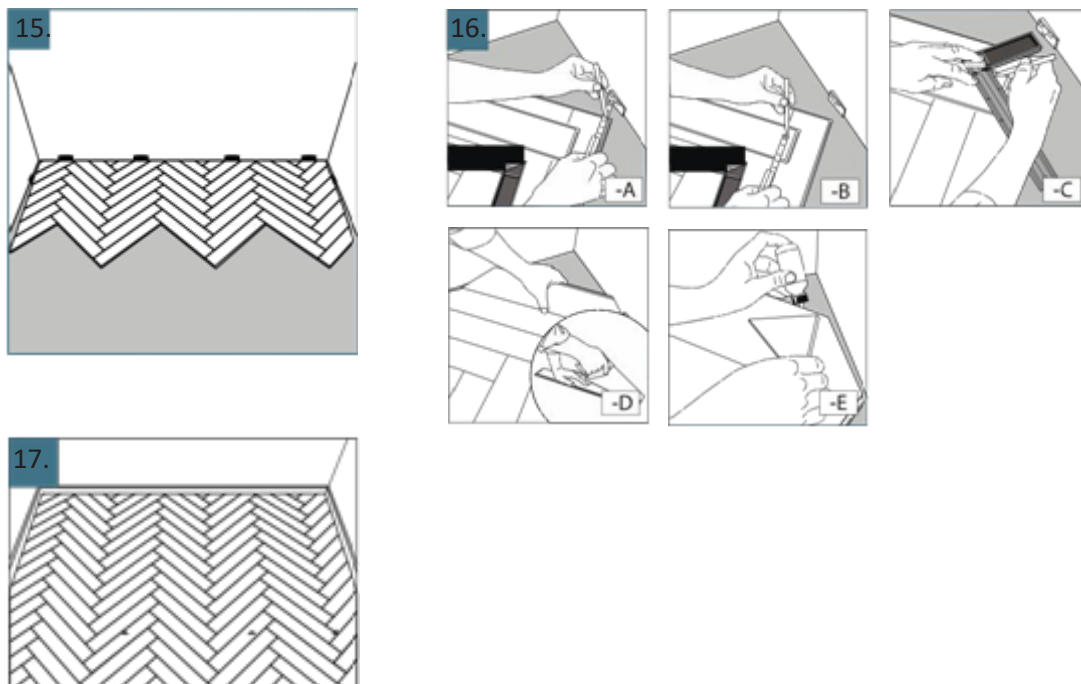

#### AFTER INSTALLATION

- Clean dust and debris regularly using a broom or vacuum with soft bristles.
- Clean any spills or liquids immediately.
- Mop as needed using a dampened mop and cleaner recommended for use on vinyl floor.
- Use protective devices under furniture, particularly items that are frequently moved. Any furniture with casters should not have ball casters. Only wide, non-staining rubber casters are to be used. Use protective mats underneath office chairs.
- Place a doormat at exterior doors to reduce dirt and debris tracked in onto floor.
- Protect the product from exposure to direct sunlight. During peak sunlight hours, the use of blinds or drapes is highly recommended.